

EP-M300

High Productivity Metal AM Machine
Metal Powder Bed Fusion



EP-M300

With a building chamber size of 305x305x450mm³, EPLUS 3D introduces EP-M300 to the successful line of MPBF™ metal AM solutions. The new EP-M300 is a marvelous metal printer that makes the production of reliable and high quality large metallic parts viable on industrial scale without requiring any tools.

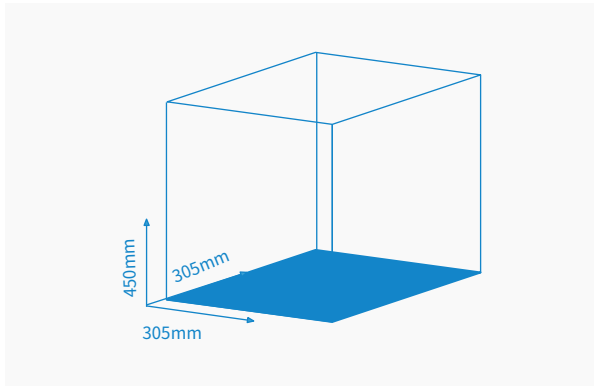

« OPTIMIZED MECHANICAL DESIGN

- Big building chamber , single or dual laser optional .
- User friendly, dual filter systems, high security
Various of performance recoating blades
·available.

» OPEN SYSTEM

- Open parameters for editing laser power, scan speed, scan direction, up and down facing surfaces etc.
- Open system ensures free choice among a wide range of metal powders in the market.
- Various material parameter packages available.
- Process software supports SLC and CLI formats.



» HIGH QUALITY

- High density and less deviation of the printed parts.
- The optimized gas flow design ensures efficient removal of smoke and splatter as well as achievement of uniform and consistent full size printing.
- Dynamic software with ability to divide the model into different sections like upper and lower surfaces, core areas and small areas etc.

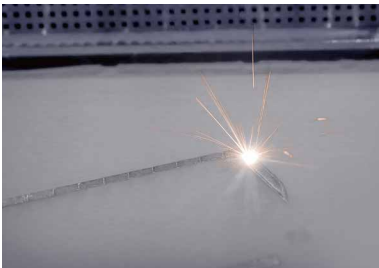

« RELIABLE & HIGH SAFETY

- Excellent core optic components from world-class suppliers and mature process control parameter algorithm provides highest part quality.
- High quality uniform part printing due to excellent control over building environment and components.
- Double locking from mechanical lock to improve safety.
- Alarming when the access door is open abnormally, to ensure the safety of use.
- Two-glove structure of the access door makes it possible to operate without opening the door.

» HIGH EFFICIENCY

- Build chamber size (XxYxZ) is up to 305x305x450mm³.
- Printing with increased layer thickness can be realized to improve production capacity.
- With in-house developed processing software (EP-Hatch), optimized scanning strategies can be achieved yielding reduced print duration.



« COST-EFFECTIVE & EASY OPERATION

- Blowback enabled coarse and fine gas-filtration system with 1000 hours.
- Highly user friendly software interface and one-click printing technology makes printing super simplified.
- Reduced gas consumption during printing ≤ 6 L/min helps reducing operation cost.

EP-M300 PARAMETER

Machine Model	EP-M300
Build Chamber (XxYxZ)	305x305x450mm ³
Optical System	Fiber Laser, 500W/1000W (single or dual-laser optional)
Spot Size	90-130μm
Max Scan Speed	8m/s
Layer Thickness	20-120μm
Building Speed	Single laser : 15~35cm ³ /h Dual laser : 25~63cm ³ /h
Material	Titanium Alloy, Aluminium Alloy, Nickel Alloy, Maraging Steel, Stainless Steel, Cobalt Chrome, Copper Alloy, etc.
Power Supply	380V, 7kW, 28A, 50 / 60Hz (Dual laser: 8KW, 31A)
Gas Supply	Ar/N ₂
Forming chamber oxygen content	≤100ppm
Dimension (WxDxH)	2990*1320*2590mm ³
Weight	2900kg
Software	EP-Hatch , EP Control
Input Data Format	STL file or other convertible format

- (1) Building speed depends on the process parameter, material and laser etc.
EPLUS 3D reserves the right to explain any alteration of the specifications and pictures.

Distributed by



Wietech 3D LLC
California - USA
+1 (909) 261-0585
info@wietech3d.com
www.wietech3d.com